

3KW UHF
Terrestrial Digital Television Broadcasting Transmitter

Technical Manual

V1.0

Beijing Duoyang Gigames

Beijing Duoyang Gigames

1. Overall Unit

1.1. Overall unit structure

3kw digital TV transmitter is mainly consisting of seven parts, i.e., exciter, amplification & control unit (ACU), power amplifier (PA) unit, central control unit (CCU), power supply control unit (PSCU), switching mode power supply (SMPS), passive components (divider, combiner, filter, directional coupler, etc.) and cooling system. Its appearance and internal structure are shown in Figure 1.

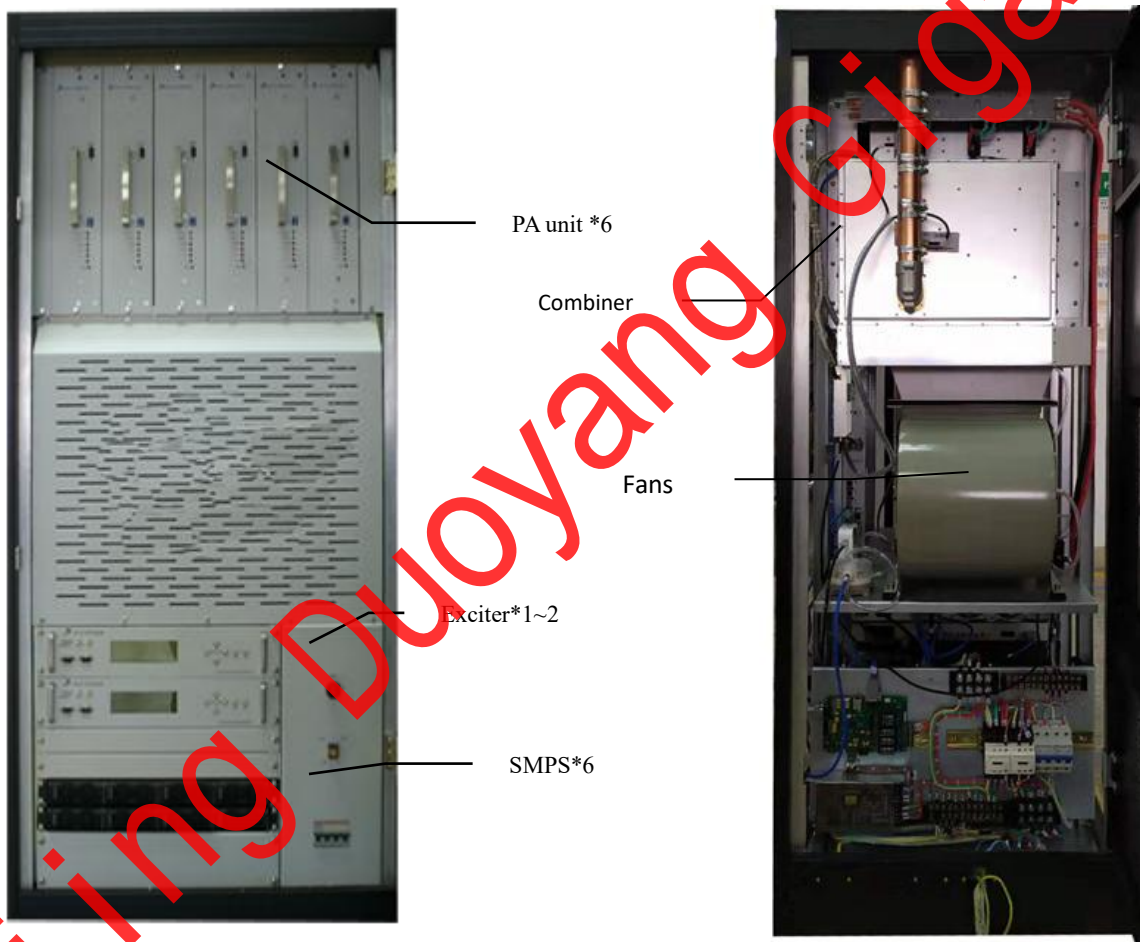

Fig.1 Front and rear view of the cabinet

1.2. Principle of the overall unit

Principle block diagram of the overall unit is shown as figure 2.

Beijing Duoyang Gigames

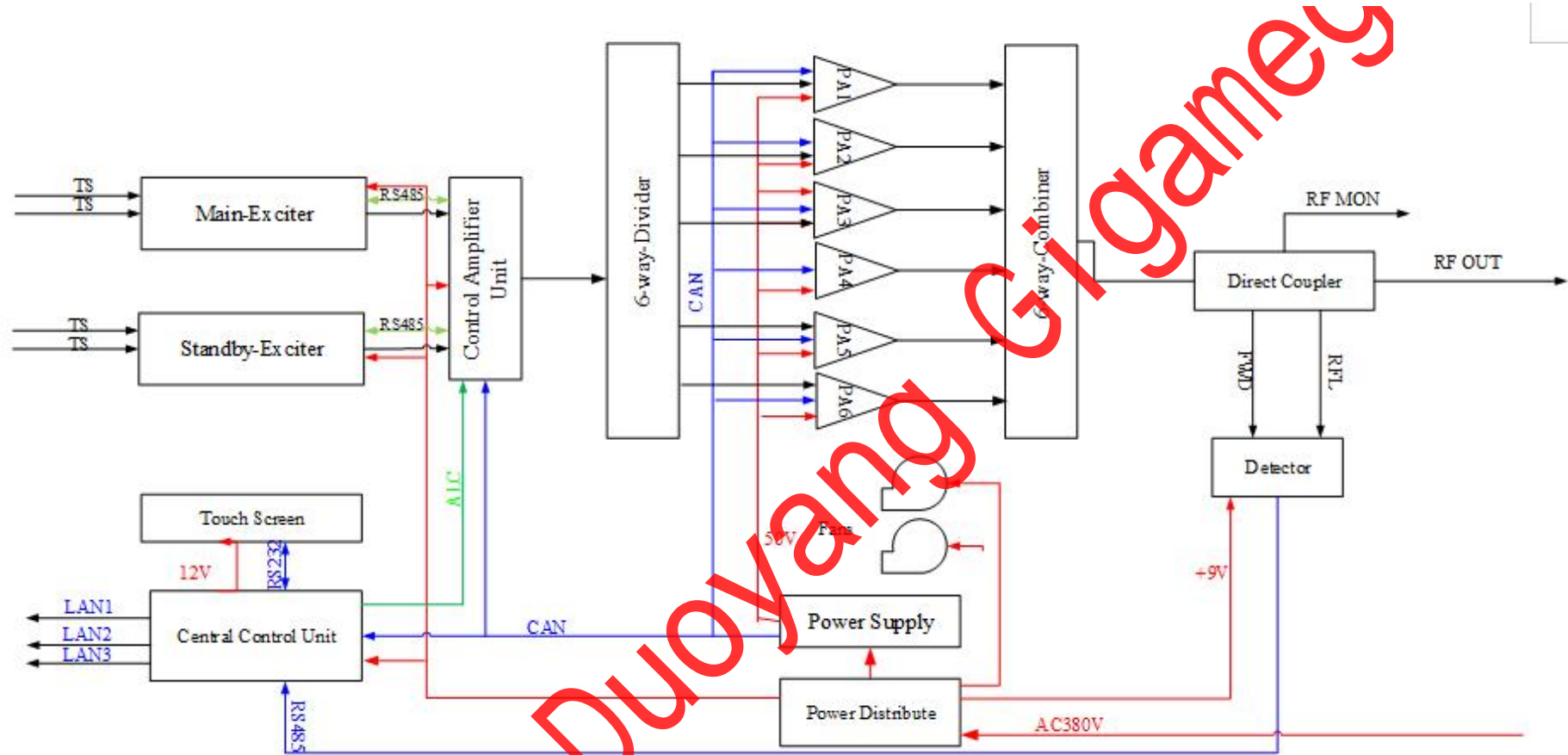

Fig. 4 Schematic diagram of UHF 3KW

1.3. SPECIFICATIONS

No.	Item	Specification
1	Frequency step size for SFN	1Hz
2	Frequency accuracy	MFN mode: $\leq \pm 100\text{Hz}$ SFN mode: $\leq \pm 1\text{Hz}$
3	Phase noise	Refer to the below “Phase noise of the transmitter”
4	RF output power stability	$\pm 0.5\text{dB}$
5	Spectrum mask	Meet specification of GB20600-2006
6	Shoulder attenuation ($\pm 3.2\text{MHz}$, measured before filter)	$\leq -36\text{dB}$
7	Inband flatness ($f_c \pm 2.591\text{MHz}$)	$\pm 0.5\text{dB}$ (non dual-pilot mode)
8	Unwanted emission inside the adjacent channel	45dB lower than inband useful emission, absolute emission power: $\leq 13\text{mW}$
9	Unwanted emission outside the adjacent channel	60dB lower than inband useful emission, absolute emission power: $\leq 13\text{mW}$
10	MER	$> 32\text{dB}$
Note: measured after filter except specify		

Phase noise of the transmitter

Offset from center frequency (Hz)	LO phase noise (dBc/Hz)
10	< -60
100	< -75
1k	< -85
10k	< -95
100k	< -110
1M	< -115

Operation condition & Dimension

1	Ambient temperature	Normal operation: 5-45°C Permitted operation: 0~50°C
2	Relative humidity	Normal operation: ≤90% (20°C) Permitted operation: ≤95% (Non condensation)
3	Atmospheric pressure	86kPa-106kPa
4	Power supply	3-phase, 380V AC; 50Hz AC, or per customer's requirement.
5	Dimension	800mm (D) *800mm (W) *1600mm (H)

Interface

- TS input: ASI, BNC, female, 75Ω.
- 10MHz input: BNC, female, 50Ω, AC coupling, $V_P \geq 600\text{mV}$ (10MHz reference signal: sinusoid wave, peak-to-peak value range: -5dBm ~ 12dBm).
- 1PPS input: BNC, female, TTL, 50Ω.
- Detection output: SMA, female, 50Ω.
- M&C interface: RJ45 LAN, WiFi, GPRS
- RF output: 3-1/8" line feed (optional IF70), 50Ω.

2. Exciter and amplification & control unit

The transmitter is equipped with corresponding model of exciter according to the user's operating requirements, its technical details please refer to the technical manual of the exciter.

The transmitter is equipped with an amplification & control unit (ACU), which is inserted between the exciters and PA units to implement three functions, i.e., the main and standby exciter switch, the transmitter output power level control and RF signal pre-amplifying. Its technical details please refer to the technical manual of the ACU.

3. Digital 600W power amplifier unit

3.1. Structure introduction

Digital 600W PA unit is composed of pre-stage amplifier, final-stage amplifier, divider/combiner, control module (including monitoring board, voltage conversion board, current sampling board) and other parts.

3.2. Schematic diagram

The schematic diagram of the PA unit is shown in figure 3.

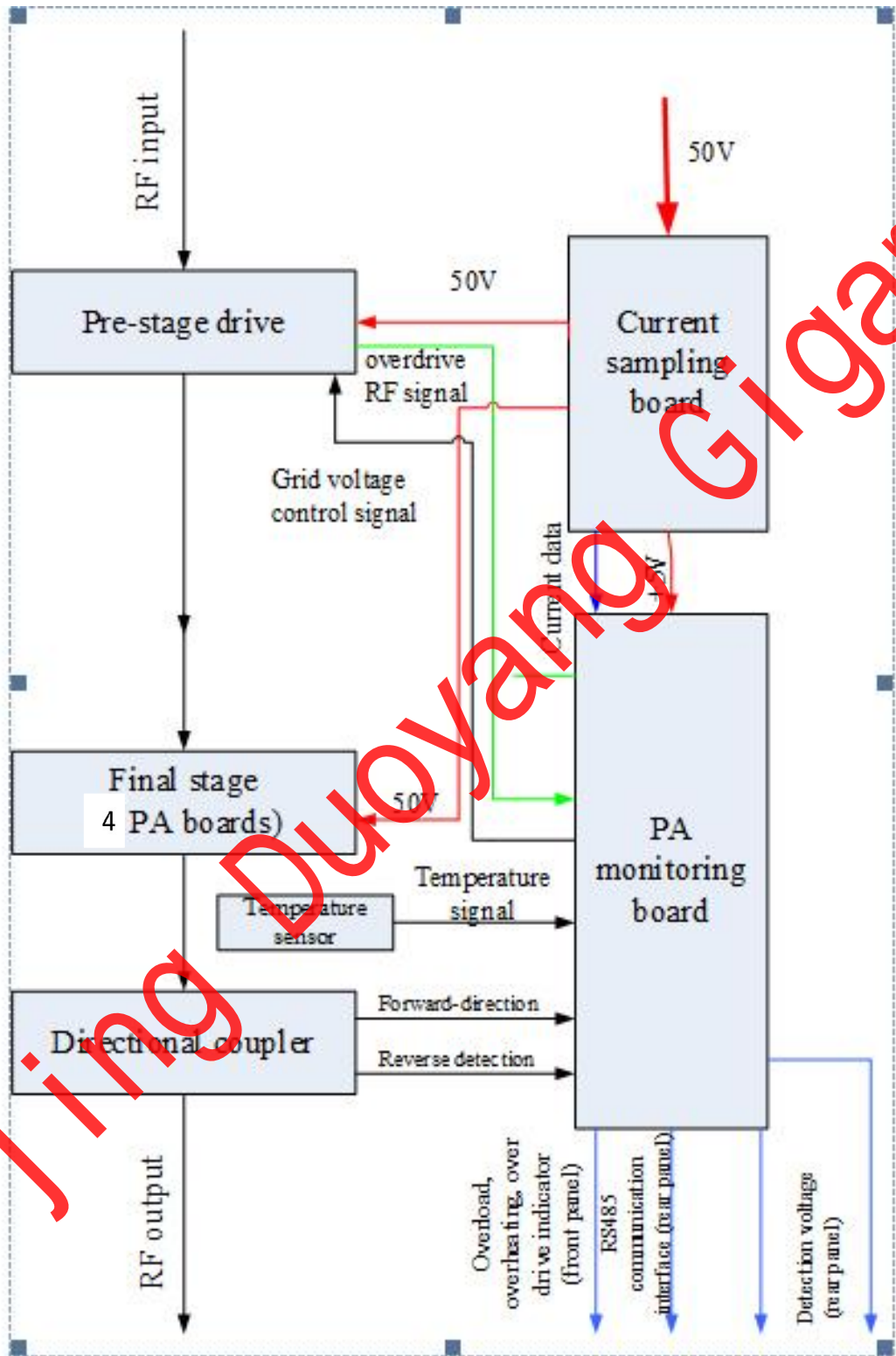

Fig. 3: PA unit schematic diagram

The PA unit has 4 final stage power amplifier boards and each board is composed of 1 LDMOS field effect tube, with each field effect tube and its input and output matching circuit constituting a single tube amplifier, three single tube amplifiers constituting a final stage power amplifier unit. Output power more than 600W.

The PA unit has good linearity and strong consistency, and is interchangeable.

The FET adopts a voltage bias method, and its grid bias voltage is formed by drain voltage through secondary voltage stabilization treatment. That is, the +50VDC drain voltage of the FET is reduced by a 2k Ω resistor and adjusted through 78L12 voltage stabilization and potentiometers of RW1 and RW2, it can reach a static grid bias value.

All the quadrature-bridge for power combination is of a coupled strip line configuration, and the power load of the isolation terminal is microstrip line 50 Ω load. If one of the amplifiers is broken, and the balanced amplifier loses balance, the isolation load will bear a part of unbalanced power.

A monitoring board of PA unit is used for sending operation parameters of the PA units to central control unit (CCU) through CAN bus interface after sampling, storage, A/D conversion and microprocessor based processing, realizing PA unit's monitoring by CCU. The main monitoring parameters include each power tube's current, power amplifier temperature, output power, switching mode power supply current and so on. PA unit is provided with the functions of self-protection control for overdrive, overload and over-temperature as well as state indication.

3.3. Specifications of PA unit

Frequency range	Working channel center frequency $\pm 16\text{MHz}$
Output power	600 $\pm 60\text{W rms}$
Input/output impedance	50 Ω /50 Ω
Input reflection loss	$\leq -20\text{ dB}$
Output reflection loss	$\leq -20\text{ dB (static)}$
Gain	$\geq 35\text{dB}$
Working state (final stage)	Class A and B
Operating voltage	50V
Over temperature protection point (light on as the criterion)	70 $\pm 5^\circ\text{C}$
Overload protection point (light on as the criterion)	VSWR ≥ 2

Over drive protection point (light on as the criterion)	Excitation power increases by 0.8dB
Phase difference of the same batch of power amplifier	$\leq 5^\circ$
Cooling requirement	Forced air cooling
Outline dimension	452mm(H)*104mm(W)*569mm(L)

3.4. Layout and description of PA unit panel

PA unit panel layout are shown in figure 7 and figure 8.

Panel alarm indicators from left to right: current indication, contact state, power amplifier tube fault, over drive, VSWR, over temperature status indication and fault reset switch.



Fig.4 Front panel of the power amplifier unit



① ② ③

Fig.5 Rear panel of the power amplifier unit

- ① RF output
- ② RF input
- ③ Power supply and control signal:

J3-1, J3-3 : +50V DC input

J3-26, J3-28: ground (GND)

J3-24, J3-26: hot plug control signal

J3-14, J3-15, J3-16: Communication line

4. Central control unit (CCU)

The central control unit is the core module of the transmitter monitoring system, which is responsible for coordinating the whole monitoring system and providing the external communication interface.

4.1. Main function

- Collect running data of the transmitter.
- Transmitter switch on/off control and parameter setting.
- Provide transmitter external M&C interface.
- Transmitter important parameter display.
- Fault alarm and fault protection.
- Provide human computer interaction interface.

The details of each function are as follows:

Collect transmitter running data

Collect running data of overall unit and its main components (exciter, power amplifier, switching mode power supply etc.) and record transmitter fault information (occurrence time, the fault point).

The transmitter operation data collected by CCU can be viewed from the touch screen

Control transmitter switch on/off

The transmitter provides two kinds of control modes for its switch on/off: local control and remote control. The local control mode is divided into manual/auto mode. In the automatic mode, the CCU provides two kinds of switch on/off mode:

- a) Touch screen button switch on/off: Startup and shutdown on the touch screen of the transmitter is controlled by soft keys. Double confirmation is needed.
- b) Remote control switch on/off: start up and shut down control on the monitoring PC.
- c) Scheduled switch on/off: the use M&C software, according to 7 days a week, 4 periods a day to set up the startup and shutdown schedule. It can choose to execute in the computer, or download the timing schedule to the transmitter to execute.
- d) Automatic control function priority: "button"> "remote control">"scheduled".

Transmitter parameters setting

Including system time settings, automatic switch on/off schedule setting, transmitter IP address settings etc.

Provide transmitter external M&C interface

CCU provides the RJ45 IP external communication interface. The monitoring PC can be communicated with CCU through dedicated transmitter monitoring software. In addition, CCU has the built-in WEB page data browsing function and data communication function, the communication protocol is serial data transmission in UDP mode, and the monitoring PC can communicate with CCU through the web browser

Monitoring PC can obtain all transmitter information from CCU, including working state of power amplifier, switching mode power supply and exciter and all kinds of alarm data, and can set the related transmitter parameters.

- a) Receive the query commands from a PC and report the status of native machine.
- b) Receive the setting commands from a PC, e.g. switch on/off mode setting, control parameters setting etc.
- c) Receive the control commands, such as startup and shutdown operation.

Transmitter parameters display

Transmitter monitoring touch screen can display the following important transmitter parameters:

- a) Time information: system time, scheduled switch on/off time, device cumulative working hours etc.
- b) Overall unit information: output power, reflected power, VSWR, overall unit fault information etc.
- c) Exciter information: working state, transmission mode, output power, voltage, small power current, temperature, standing wave etc.
- d) PA unit information: the number of PA units, output power, voltage, current, fault information (over temperature, over drive, over VSWR)
- e) SMPS information: the number of switching mode power supply and the parameters of each SMPS.

Alarm and fault protection

When the transmitter is overload, overcurrent and over temperature, or power amplifier, cooling system and other major components are occurring serious failure, CCU can turn off the exciter RF output.

According to the actual requirement, alarm threshold for output power and VSWR can be set in a local or remote mode.

Human-machine interaction

Through the monitoring touch screen, the working parameters of the main components can be checked and the system parameters can be set.

Remote M&C function

The transmitter has the functions of remote control and monitoring, including the working state monitoring of the transmitter, the transmitter protection and fault alarm monitoring etc, details as follows:

- a) Overall output power, reflected power, standing wave, working voltage and current; SMPS and PA tube working state is normal or not; the exciter working parameters and power supply controller operating state is normal or not.
- b) Alarm contents include over temperature, excessive standing wave, over drive, loss of RF output, overhigh or overflow power, etc.
- c) The settable contents include local IP address, system date and time, scheduled switch on/off table, output power protection threshold, manual / automatic switch mode, local / remote switching mode, etc.

Exciter communication and control

The overall unit provides main-standby dual exciter interface and main/standby exciter can realize on-line automatic switching. Under the circumstances of main exciter damaged or no output, it can automatically switch to the standby exciter within one second and it also supports the manual switching.

4.2. Main control board

The main control board is the core of CCU, using ARM as the main control chip and configured with input channel, system clock, memory, RS485 interface, CAN bus interface and RS232 interface etc.

The main control board realizes the human-machine interaction function through touch screen and

completes communication with the PC machine and other "slave" inside the equipment through the CAN bus interface.

4.3 Operation interface of 3KW transmitter

The local control of 3KW transmitter serves as the control interface of human-computer interaction (HCI) via color touch screen, including transmitter's local operation, real-time query of working parameters, general parameter setting and log query. The details of menu are as follows:

1) Main Interface



[Description]

The main interface of the whole machine mainly includes the display of the whole machine system diagram (refer to the main interface block diagram), the composition of the transmitter is shown in detail through the block diagram, and the direction of signal flow is shown through interconnection. Display the corresponding part's working state on the basis of box's color. For example, Ex A and Ex B refer to the master exciter A and the standby energizer B. The exciter switch is the main and standby exciter switch unit, which is located inside the ACU. In the middle is the function menu and the status, Local represents local control, showing green indicates that the current control mode is local control; Scheduled is the timer switch mode, showing gray indicates that this function is not currently enabled; Remote is the remote telemetry function, showing green indicates that remote control works. can be through the PC

remote control transmitter switch.

The bottom line is the transmitter's local operating function key, which includes power on, power off, status, settings, logs, information, and details on how each function key operates and is set to be individually described below.

2) Welcome screen

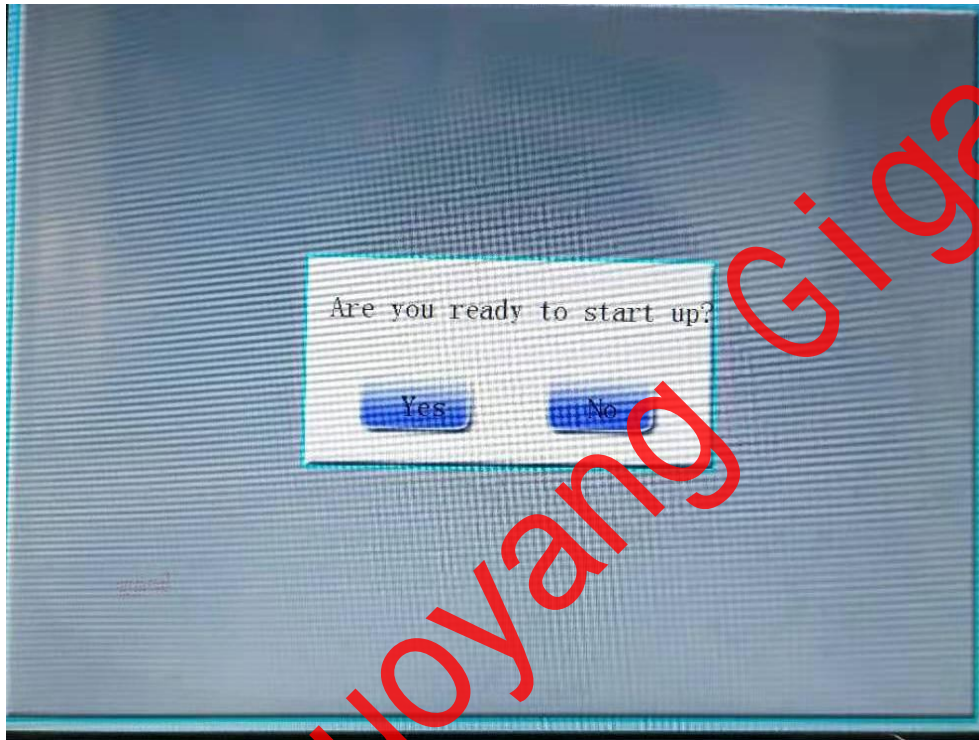

[Description]

The foregoing figure is the example of welcome screen, and the user can log into this screen after pressing down the “On” button on the main interface. For security reason, second confirmation is needed for start-up. The user shall click “Yes” for confirming the start-up operation, and click “No” to cancel in case of any misoperation. After clicking “No”, the user can return to the main interface to carry out other operation.

3) System Information Interface

[Description]

The image above is the system information interface, which enters when you touch the main interface information key. Through this interface, the software version information of the main components of the machine can be obtained, including main control, electronic control, power amplifier, and exciter and so on. Querying the software version information of the equipment can ensure that the late maintenance or troubleshooting go smoothly. This interface can only be read and cannot be set. When the reading ends, click the Back key to return to the main interface.

4) Shut-down screen

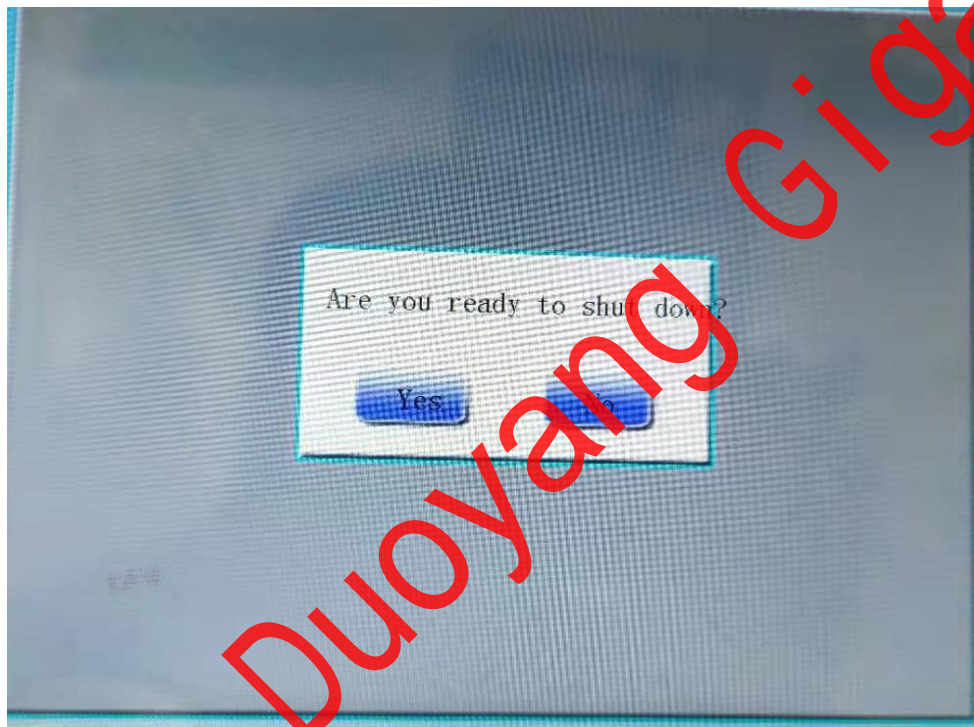

[Description]

The foregoing figure is an example of shut-down screen, and the user can enter into this screen after pressing down the "Off" button on the main interface. For security reason, second confirmation is needed for shutting down the machine. The user shall click "Yes" for confirming the shut-down operation, and click "No" to cancel in case of any misoperation.

5) Log Query Interface

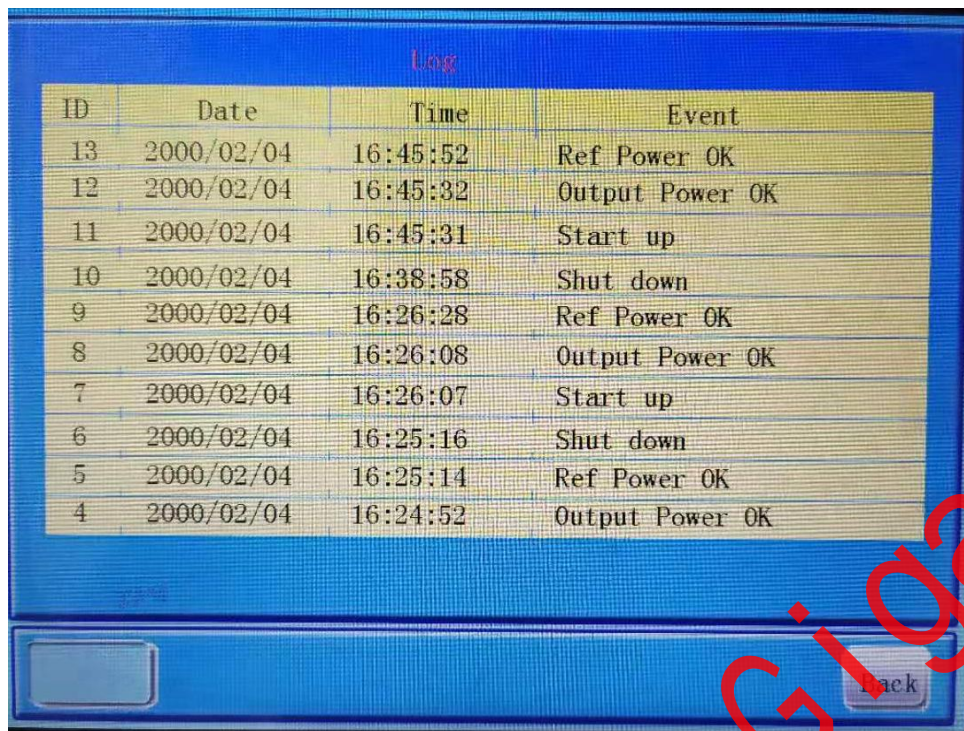

ID	Date	Time	Event
13	2000/02/04	16:45:52	Ref Power OK
12	2000/02/04	16:45:32	Output Power OK
11	2000/02/04	16:45:31	Start up
10	2000/02/04	16:38:58	Shut down
9	2000/02/04	16:26:28	Ref Power OK
8	2000/02/04	16:26:08	Output Power OK
7	2000/02/04	16:26:07	Start up
6	2000/02/04	16:25:16	Shut down
5	2000/02/04	16:25:14	Ref Power OK
4	2000/02/04	16:24:52	Output Power OK

[Description]

The image above is the log query interface, which enters when you touch the log key of the main interface. Detailed information about the operation record of the equipment and the working status of the transmitter, including the specific time of switch on, switch off, and failure, can be queried. This interface can only query log and the records cannot be modified, when the query ends, click Back key to return to the main menu.

6) Alarm Threshold Setting Interface

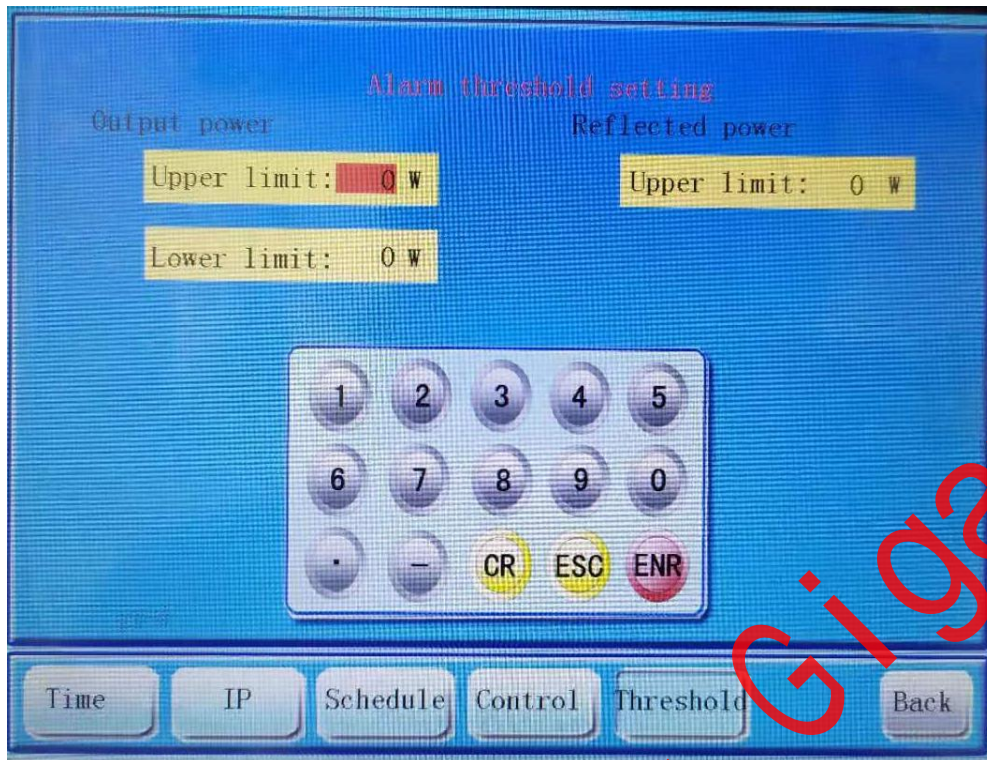

[Description]

The image above is the alarm threshold setting interface, when touch the main interface set key, enter the settings sub-interface. Then click on the function menu below to set the Threshold sub-menu and enter the interface as shown above. The upper and lower limit of output power and the upper limit of transmitting power can be set. First click on the corresponding setting of the specific blank, through the interface of the numeric keypad, input the desired power value, unit W, after input, click the ENR key on the keypad to complete. In case of an input error, cancel the input with the CR key or the ESC key. When the settings are complete, click the Back key to return to the main menu.

7) Setting interface in the on/off control mode

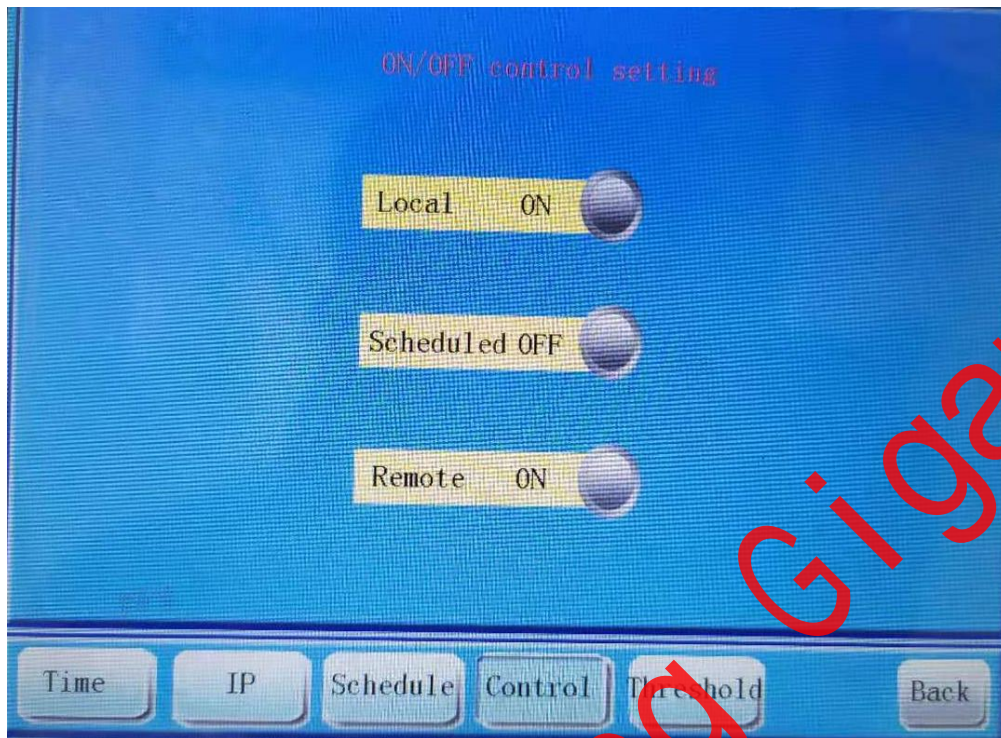

[Description]

The image above is the Switch Control Mode Settings interface, which goes into the Settings sub-interface when you touch the main interface Config setting keys. Then click on the function menu below to set the sub-menu for Control Mode on Switchgear, and enter the interface as shown above. There are three control switch mode options, each mode ON and OFF status can be switched through the corresponding column above the round button, after settings, click back to return to the main menu.

8) Setting interface for timing on/off

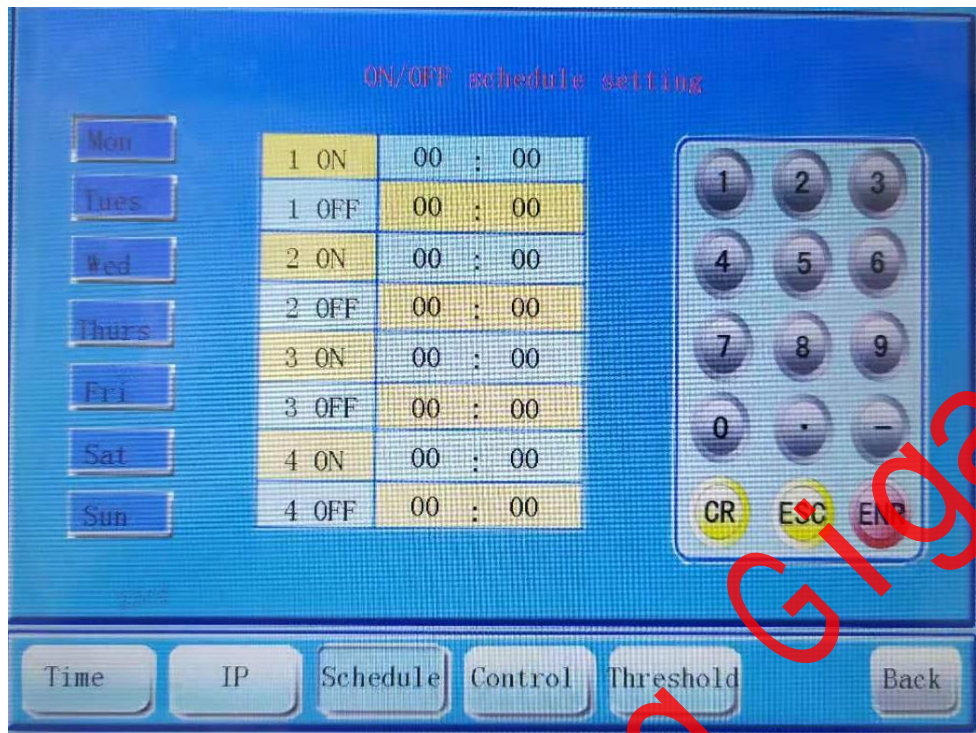

[Description]

The image above is the timer switch setting interface, which goes into the settings sub-interface when you touch the key of the Schedule timer setting on the main interface. Then click on the following one-line feature menu, Schedule, to set the sub-menu, and enter the interface as shown above. The left column shows the day of a week. First of all, the user can click and choose the day at the left column for time switch setting. The middle column consists of four different periods of the day, and the user can select the specific time for turn it on and turn it off. The right-most is the input keypad, you can input the specific value, press the ENR key to confirm, after the settings are complete, click back to return to the main menu.

5. Power supply control unit

5.1. Overview

The power supply control unit (PSCU) is composed of power distribution control system and an AC contactor, constituting the “power supply and fan control subsystem” with SMPS detection and control board (back side of SMPS), as shown in figure 6.

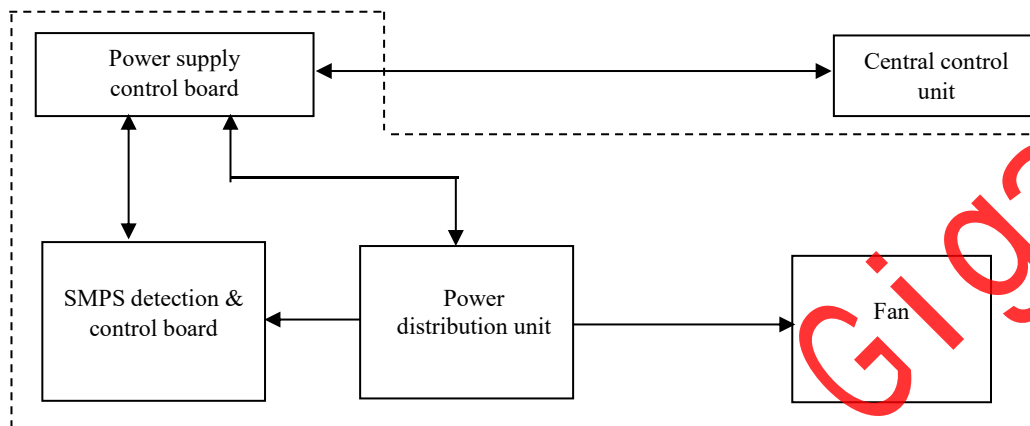

Fig. 6 Power supply and fan control system

Main functions:

- Collect state data of SMPS and send the data to central control unit.
- Control power supply of overall unit.
- Control power on-off sequence of various components.
- Control the transmitter switch on/off mode.
- Alarm display.
- Interlock function. PSCU reserves interlocking interface to the external equipment, supporting external dummy load, coaxial switch or customer required other interlock protection equipment, to prevent transmitter startup without starting the interlocking equipment or interlocking equipment startup not in place.
- External electricity flash falling protection: PSCU program has automatic data storage function for external electricity flash falling, power failure recovery can use configuration parameters before power off and automatically returns to work.

5.2. Structure and function

5.2.1. Front panel and cabinet layout

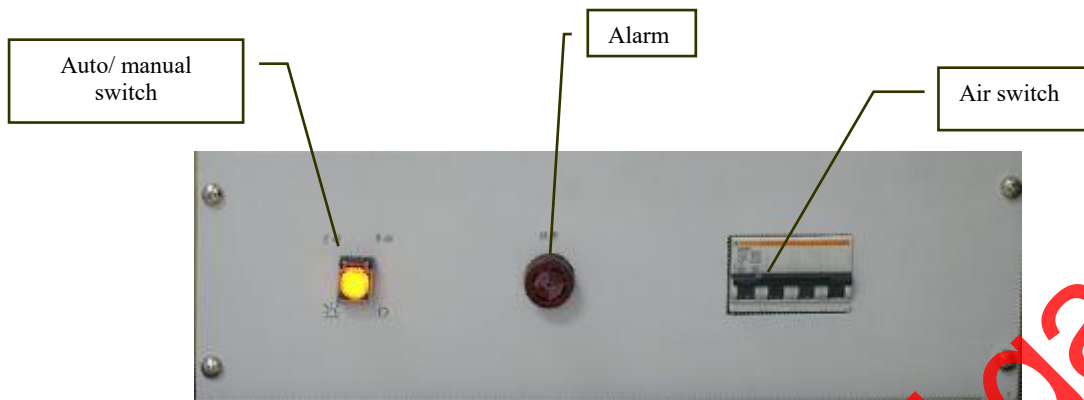

Fig. 7 Power supply control and distribution unit front panel

5.2.2. PSCU function

- Control the transmitter switch on/off : In the auto switch on/off mode, it receives on/off command from CCU and sends power on/off control signal to each AC contactor of power distribution according to program to completes automatic switch on/off of the transmitter.
- SMPS management: power supply control board controls SMPS on/off through SMPS detection & control board, collects SMPS information and reports to CCU.
- Report to CCU about SMPS information and fan working status through Can bus; receive and execute CCU commands
- Provide 9v/ 12V power supply for the whole M&C system.

5.2.3. Power supply control board

The power supply control board is the main control board of the power supply and the fan control subsystem. It includes CPU and watchdog circuit, address decoder, solid state relay controller for switch on/off, switch on/off button control, RS232 interface, DC fan control and spare detection interface, etc..

In the automatic switch on/off mode, the interface J4 and J1 respectively control the main AC contactor and lacking phase alarm indicator. LED tube D1 and D4 respectively indicate the corresponding solid state relay contacts on or off, J2 and J3 for backup.

6. Power distribution unit

6.1. Overview

Power distribution unit is the power source of all active parts of the transmitter. It mainly distributes power to the following units: cooling system, central control unit, exciter, power supply control unit, power amplifier unit, switching mode power supply.

The power distribution unit is mainly composed of air switch (on the front panel of power supply control unit), AC contactor, phase protector and lightning arrester.

6.2. Function

The main functions of the power distribution unit are as follows:

- It distributes power for cooling system, central control unit, exciter, power supply control unit, power amplifier unit and switching mode power supply.
- It serves as actuator of power on-off of each unit and is controlled by the power supply control unit to switch on or off the power supply of the designated unit and realizes the logic control of the system power switch .
- Switch on/off indication: It indicates the current transmitter working state on the panel. When the transmitter is powered up, the green light is turned on; when the transmitter is powered off, the red light is on.
- Manual / automatic switch-over: When switching to manual, the automatic control system is disconnected, the whole machine is powered up directly; when switching to automatic, each unit is controlled by automatic control system.

6.3. System power distribution description

The external AC 380V power supply is divided into two ways through the terminal behind transmitter control cabinet, one way enters the air switch on the front panel of the power supply control unit, and the other way enters the lightning arrester as an overall unit lightning protection.

The 380V power supply into the air switch is divided into Three ways:

The second way is sent to main AC contactor to supply power for switching mode power supply. When the main AC contactor is picked up, the power is on, and the SMPS starts to supply power for PA units.

The third way is sent to fan relay.

The fourth way is fed into the switching mode power supply of the power supply control unit to

supply power for it. The 9V DC output power supply of this switching mode power supply is sent to the power supply control board and the power management board.

7. Switching mode power supply

7.1. Overview

The transmitter adopts AC380V three-phase four wire balanced input to ensure the same power for each phase. The transmitter has 9 SMPS units and a single SMPS is 2.5kW, with large power capacity redundancy. The input voltage of the switching power supply is AC220V. The three SMPS units adopts parallel current sharing output redundancy design. When a single SMPS fails, the transmitter can still work properly

7.2. Panel layout and interface

The front and rear panels of the SMPS unit are shown in figure 8 and figure 9.

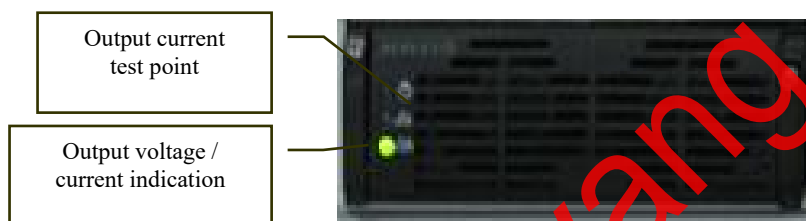

Fig. 8 Front panel of SMPS



Fig. 9 Rear panel of SMPS

7.3. SMPS specification

Output rated voltage	50V
Output rated current	50A
Output voltage regulation	$\leq \pm 0.5\%$
Output current regulation	$\leq \pm 0.5\%$
Peak to peak ripple voltage	$\leq 200\text{mV}$ (20MHz oscilloscope)
AC input voltage range	220V $\pm 15\%$
Output overvoltage protection point	50V $\pm 1\text{V}$
Output overcurrent protection point	50A \sim 52A
Power factor	≥ 0.92

Current sharing precision	$\geq\pm 5\%$
Output short circuit protection	Yes
Lightning protection	Yes
Conversion efficiency	$\geq 90\%$
Over temperature protection	$80^{\circ}\text{C}\pm 3^{\circ}\text{C}$
Working temperature	$0^{\circ}\text{C}\sim 45^{\circ}\text{C}$
Storage temperature	$-30^{\circ}\text{C}\sim 60^{\circ}\text{C}$
Relative humidity	$\leq 90\%$
Altitude	$\leq 2000\text{m}$
Insulation strength	input to casing and input to output: AC1500V output to casing: DC500V (This machine has lightning protection measures)
Dimension	70(W)mm x 265(H)mm x 380(D)mm

8. Passive component

The passive component subsystem is composed of power divider / combiner, band-pass filter and directional coupler.

8.1. Microstrip Four-way divider

Microstrip 4-way divider adopts microstrip line structure and realizes uniform distribution of 4 way power in a wide frequency range and ensures high isolation between the ports and low reflection coefficient. Divider is built with absorption load.

Technical specification

Frequency band	470-860MHz
Insertion loss	$\leq 0.35\text{dB}(\text{max})$
Isolation	$\geq 25\text{dB}$
Reflection loss	$\geq 26\text{dB}$
Unbalanced	$\leq 0.2\text{dB}(\text{max})$
Phase unbalanced	$\leq 5^{\circ}(\text{max})$
Input power	$\leq 1\text{W}$

The microstrip 6-way divider has 1 input port and 6 output ports. The connector type is SMA.

8.2. Strip 4-way combiner

Strip 6-way combiner adopts suspended stripline structure and realizes three way power combination in a wide frequency range, and ensures the isolation between the ports.

Technical specification

Frequency band	470-860MHz
Insertion loss	$\leq 0.35\text{dB}(\text{max})$
Isolation	$\geq 25\text{dB}$
Reflection loss	$\geq 26\text{dB}$
Unbalanced	$\leq 0.2\text{dB}(\text{max})$
Phase unbalanced	$\leq 5^\circ(\text{max})$
Input power	$\leq 500\text{W}$
output power	6kW

Stripline 6-way combiner has four input ports, one output port and four load ports. The input and load port connector type is L29-KFD. The output port is $\Phi 79.4$ direct feed.

8.3. Band-pass filter

The filter adopts six cavity coaxial form, fully meeting the requirements of digital TV transmitter spectrum mask.

Technical specification

Input / output impedance	50 Ω
Reflection loss	$\geq 26\text{dB}$
Insertion loss	$\leq 0.5\text{dB}(\text{max})$
Channel bandwidth	Channel center frequency $\pm 3\text{MHz}$
	$\pm 2.8\text{MHz} < 1\text{dB}$
	$\pm 3.2\text{MHz} \geq 4\text{dB}$
	$\pm 5\text{MHz} \geq 35\text{dB}$
	$\pm 11\text{MHz} \geq 40\text{dB}$
Maximum power	$\geq 15\text{KW}$

8.4. Directional coupler

The RF power of the transmission channel is coupled out, which is used as an indication and protection of transmitting power, or to monitor RF modulated waveform. It has a strong direction. The coupled power value is related to the transmission power of the transmission channel.



Fig. 15 Directional coupler drawing

Technical specification

Frequency range	470-860MHz
Coupling factor	Meet the requirements of the transmitter (see the equipment identification)
Directional	≥24dB
main way VSWR	≤1.05

Φ79.4 three-port directional coupler has 2 output power detection ports and 1 reflected power detection port. Sampling signal of directional coupler is the DC voltage (related to output power or reflected power) amplified by detector and an RF monitoring signal.

9. Cooling system

9.1. Overview

A good cooling system is an effective guarantee for the normal operation of the transmitter. This transmitter adopts air cooling method.

9.2. Cooling system components

The whole cooling system adopts two low noise centrifugal fans, which can be used for cooling 3 power amplifier units. The dual centrifugal fan can provide redundant backup. The two fans can be powered independently and switched on/off respectively and realizes online maintenance

The amplifier radiator adopts advanced heat dissipation aluminum shovel teeth technology, with high efficiency of heat dissipation.